

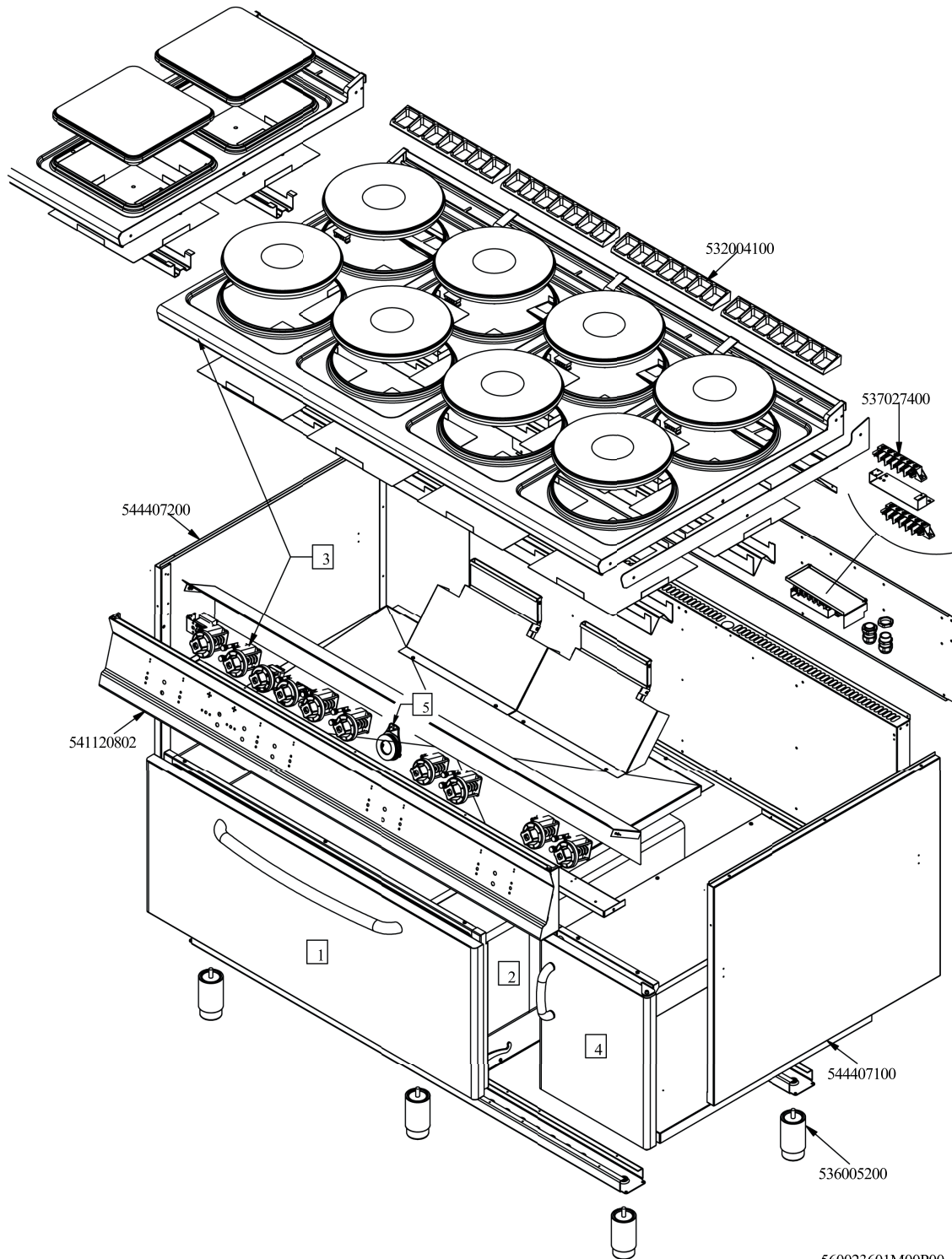

RM 900
 Platný od 1.5. 2019
 CF8-916ETV, CFQ8-916ETV



560023601M00P00



Objednáací kód	Popis v ENG
544407100	RIGHT SIDE PANEL RANGE 90 LINE
536005200	INOX LEG 2" 120-180 M10
541120802	
544407200	RIGHT SIDE PANEL RANGE 70 LINE
532004100	FLUE GRID L=370 90LINE (RAF)
537027400	TERMINAL BLOCK THREEPHASE 40A
-	-
-	-
-	-
-	-
-	-

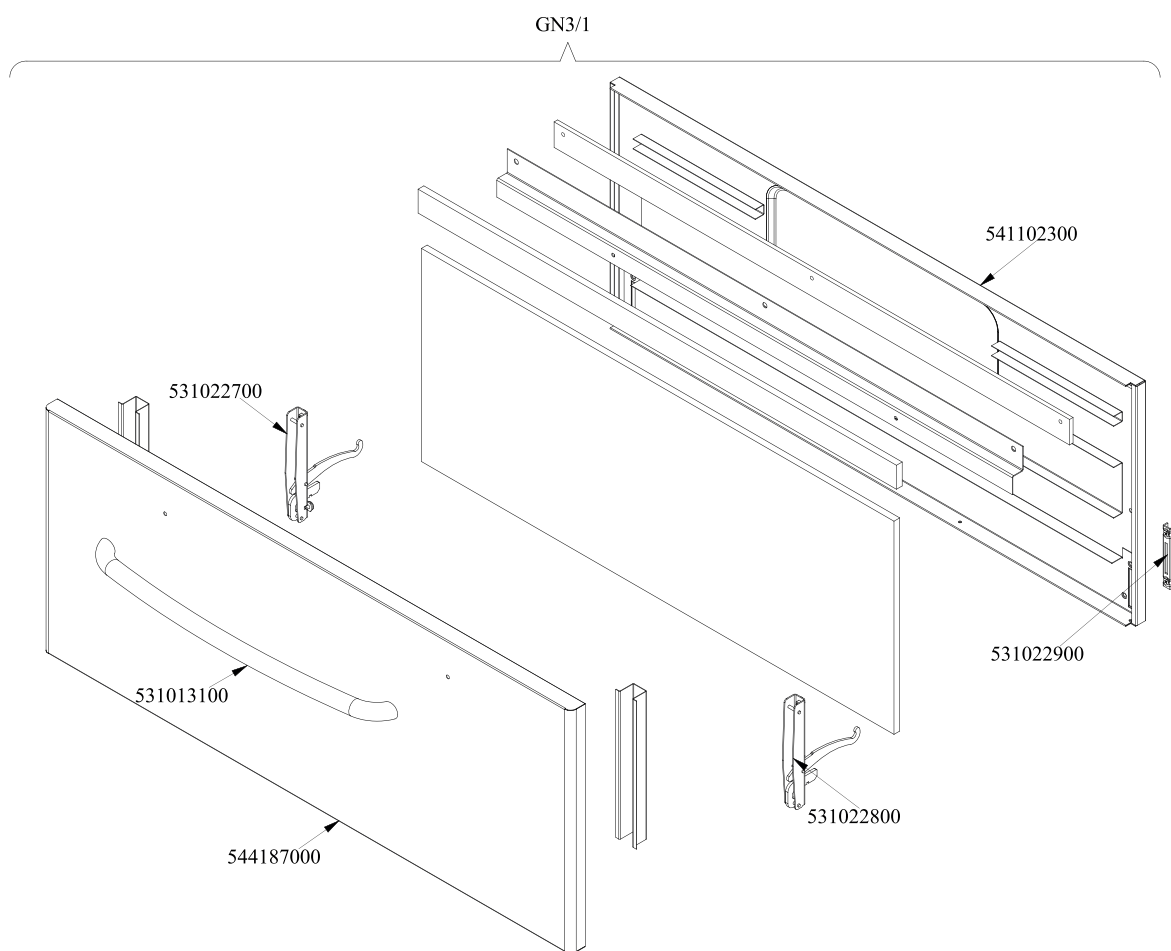

560099900M01P00



Objednačí kód	Popis v ENG
541102300	GAS OVEN INNER DOOR GN 3/1 S.70
531022800	531022800N DOOR HINGE S.70
531022900	HINGE ROLLER HOLDER FOR 700-OVEN
531013100	OVEN DOOR HANDLE OF 70/90-LINE
531022700	LEFT OVEN DOOR HINGE 70LINE
544187000	OVEN DOOR GN 3/1 S.70

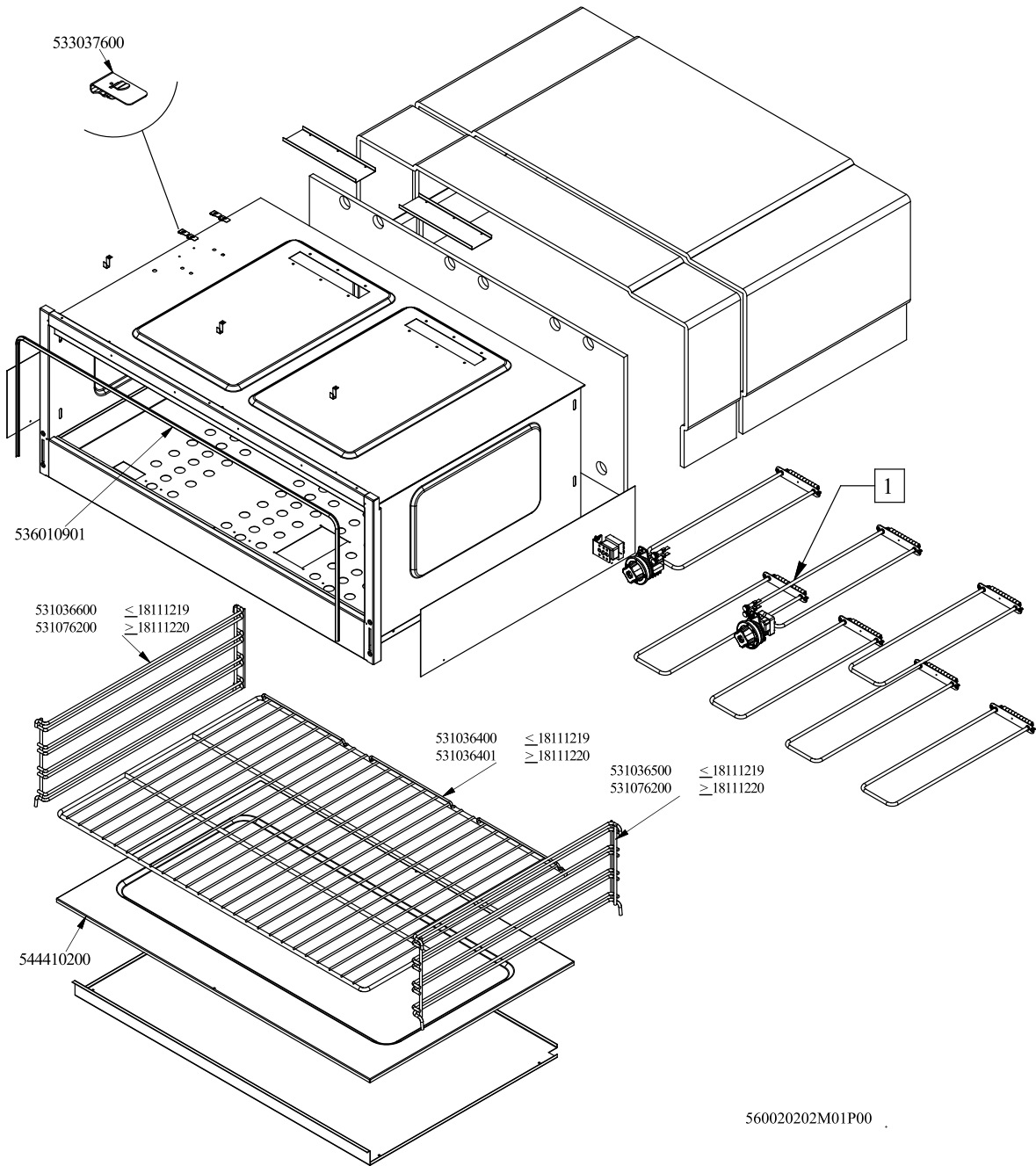



Objednací kód	Popis v ENG
544410200	90 ELECTRICAL OVEN BOTTOM GN3/1
533037600	LOCK SPRING FOR BULB
531036600	LHD RACK HOLDER FOR OVEN S.90
531076200	
531036500	RHD RACK HOLDER FOR OVEN S.90
531036400	OVEN GRID GN 3/1 FOR 90 LINE
531036401	
536010901	GAS OVEN GASKET GN 3/1 (1668)
-	-

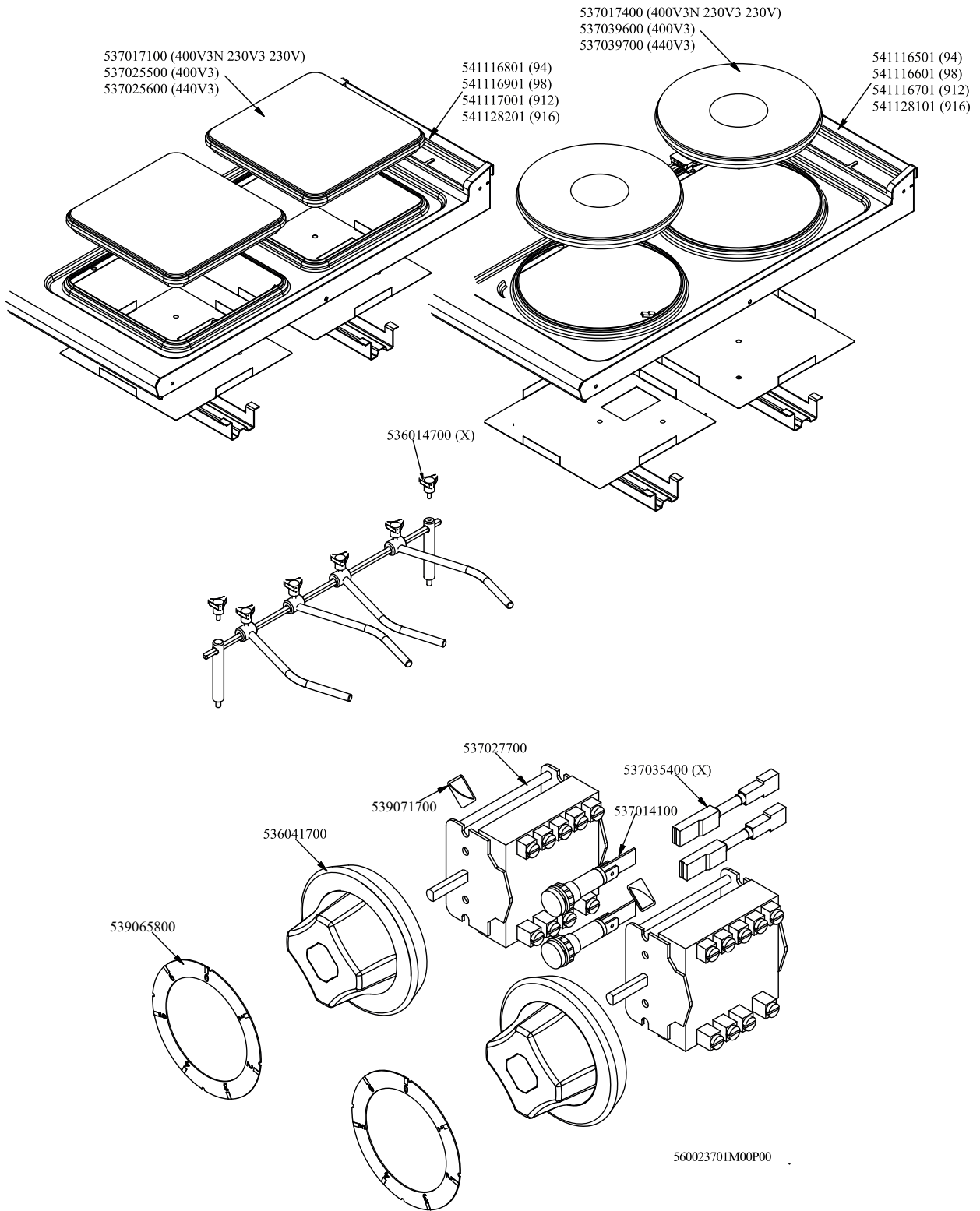



Objednačí kód	Popis v ENG
539071700	ADHES.LABEL FOR RING GREEN SIGN.
537014100	WHITE WARNING LIGHT 250V
537035400	HEATING ELEMENT 00003W 330KOHM W/F
537027700	COMMUTATOR 7 POSITIONS S.43 32A
536041700	SILVER CHROM. KNOB Ø77 4P.G.Ø06X4,6
539065800	BLACK ADESIVE DISK FOR PC-E
536014700	3 DRILL WHEELS
537017100	PLATE 300X300 W4000 V230
537025500	PLATE 300X300 W4000 V400
537025600	PLATE 300X300 W4000 V440
537017400	ELECTRICAL PLATE D.300 W3500 V230
537039600	ELECTRICAL PLATE D.300 W3500 V400
537039700	ELECTRICAL PLATE D.300 W3500 V440
541116501	
541116601	
541116701	
541128101	
541116801	
541116901	
541117001	
541128201	

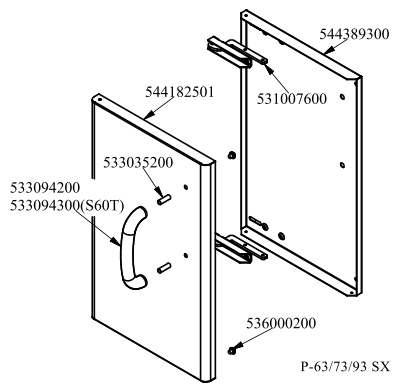

P-63/73/93 SX

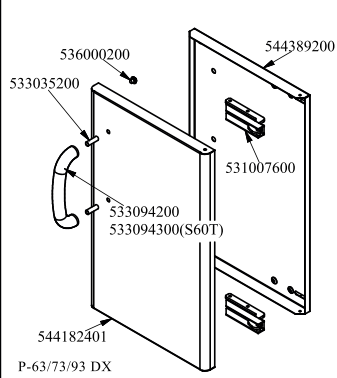

P-63/73/93 DX

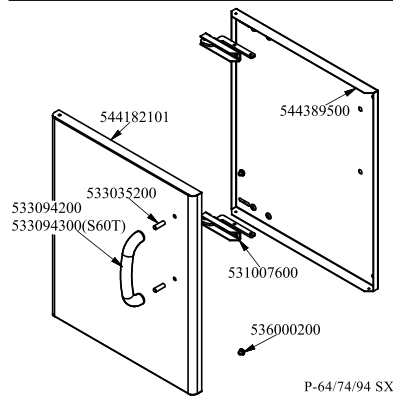

P-64/74/94 SX

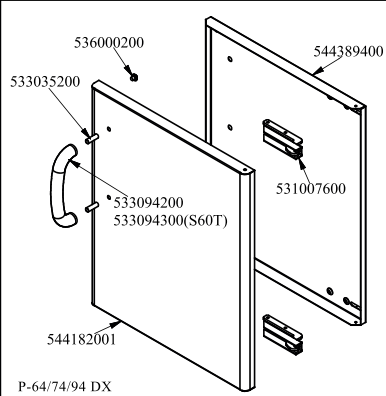

P-64/74/94 DX

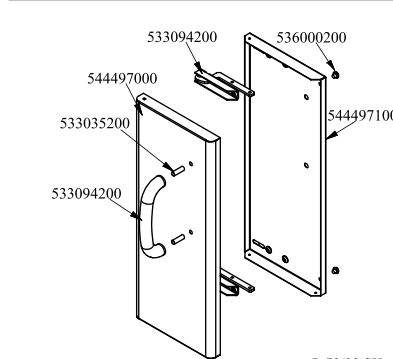

P-72/92 SX

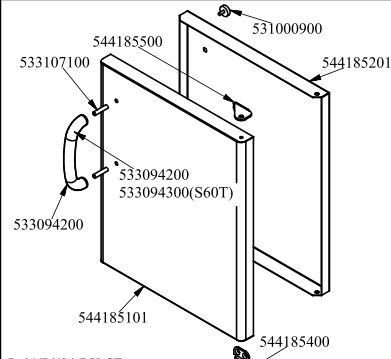

P-64/74/94 DX CF

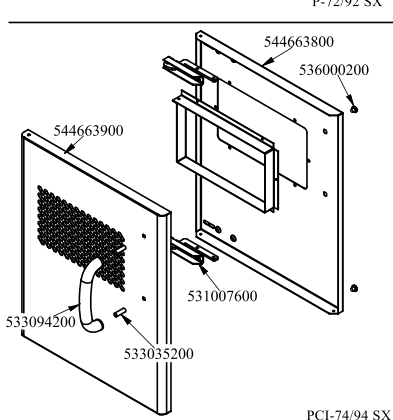

PCI-74/94 SX

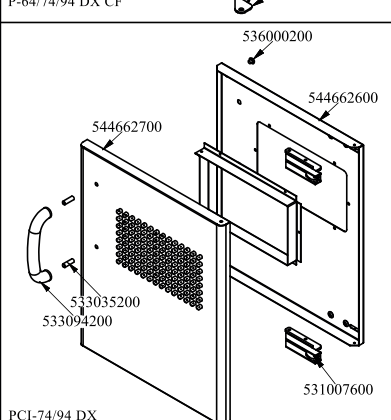

PCI-74/94 DX

560012802M00P00



Objednací kód	Popis v ENG
544185101	RIGHT DOOR 74 CF
533107100	HANDLE SPACER OF CF-70
533094200	S/S HANDLE FOR 70/90 SERIES
544185400	LOWER DOOR HINGE FOR COMPARTME CF70
544185500	UPPER DOOR HINGE FOR COMPARTME CF70
544185201	INNER DOOR * 74DX
531000900	MAGNET §22 KG.3 WITH DISK
536000200	D.12 H.4 BUMPER
544182001	RIGHT DOOR 74
531007600	DOOR HINGE
544389400	
533035200	HANDLE SPACER
544182101	LEFT DOOR 74
544389500	INNER-DOOR OF LHD 74
544182401	RIGHT DOOR 73
544389200	
544389300	
544182501	LEFT DOOR 73
544497000	
544497100	
544663900	LHD 74 DOOR FOR PCI
544663800	74 LHD OVEN INNER DOOR FOUR PCI
544662700	DOOR 74 DX PCI
544662600	
533094300	S/S HANDLE FOR 600T.LINE

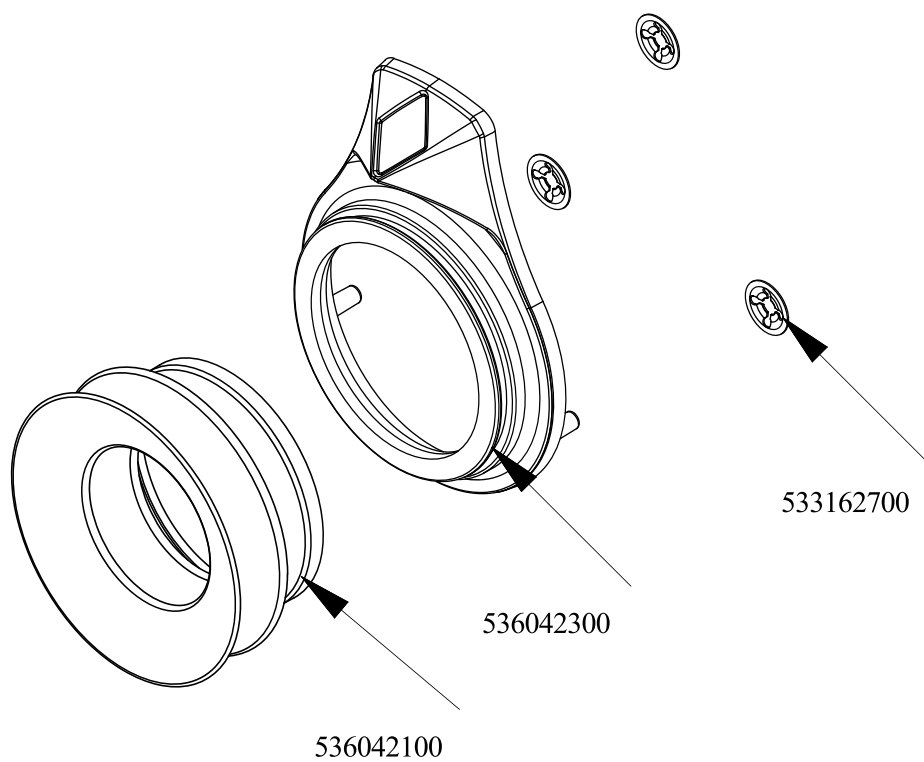

560125700M00P00



Objednací kód	Popis v ENG
536042300	SILVER CHROM. RING FOR KNOB Ø77 4 P
536042100	SEAL CASING FOR KNOB Ø77 4 P
533162700	PROCESSING CODE



CF8 - 916 ETV, CFQ8 - 916 ETV
 Platný od 1.5.2016
 do 30.4.2019

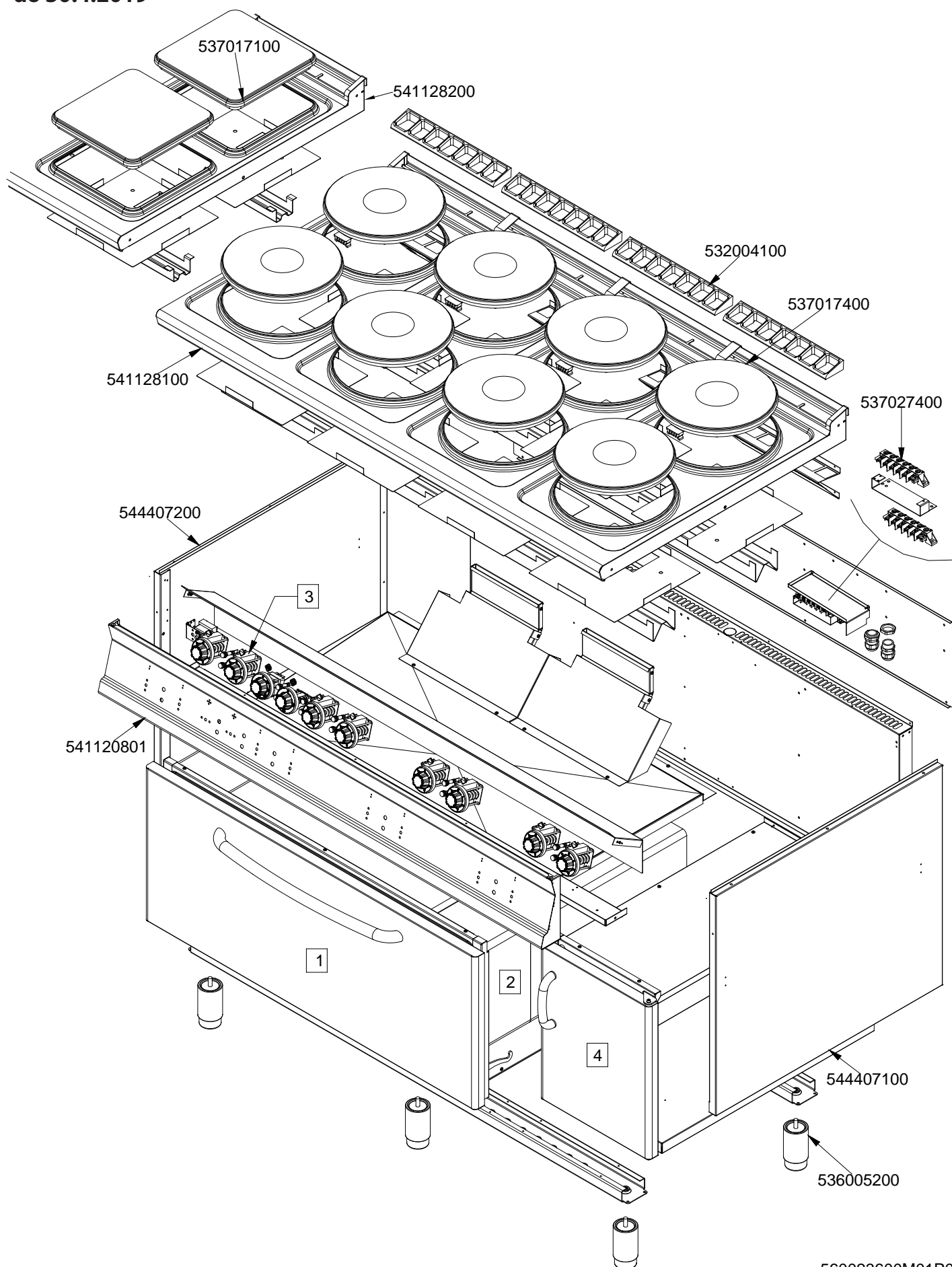

CF8 - 916 ETV, CFQ8 - 916 ETV

(1)

Platný od 1.5.2016

do 30.4.2019

GN 2/1

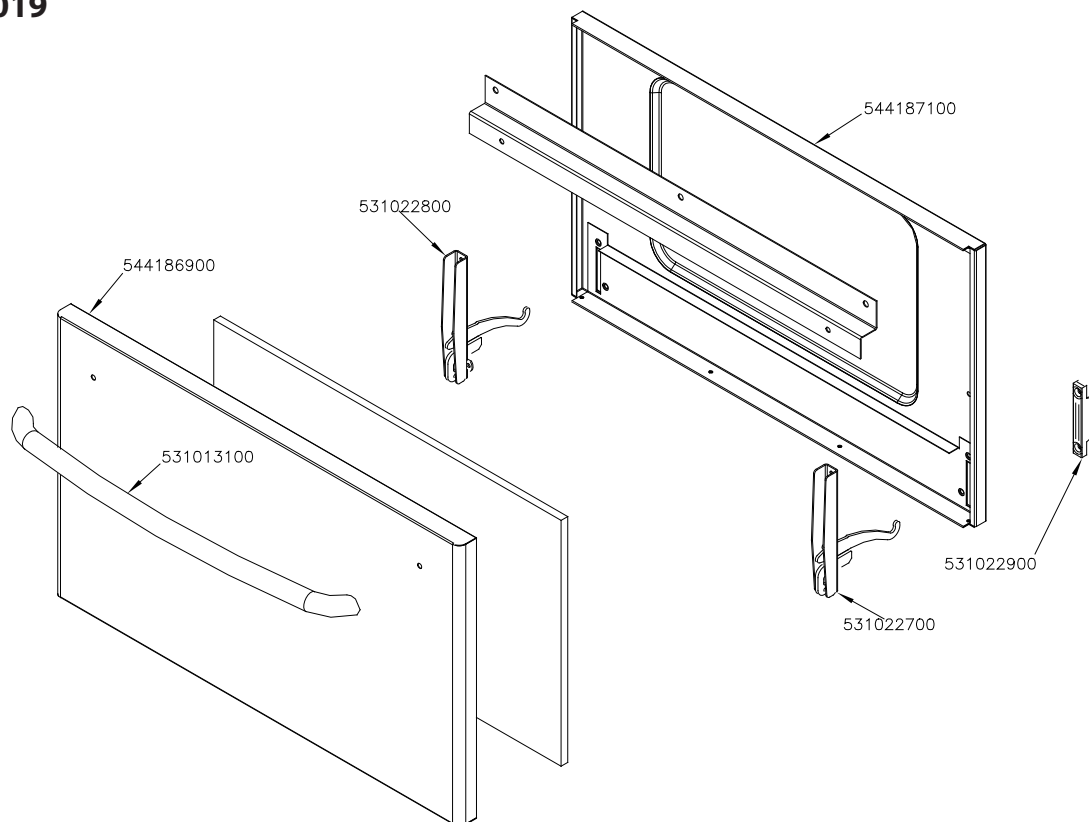

GN 3/1

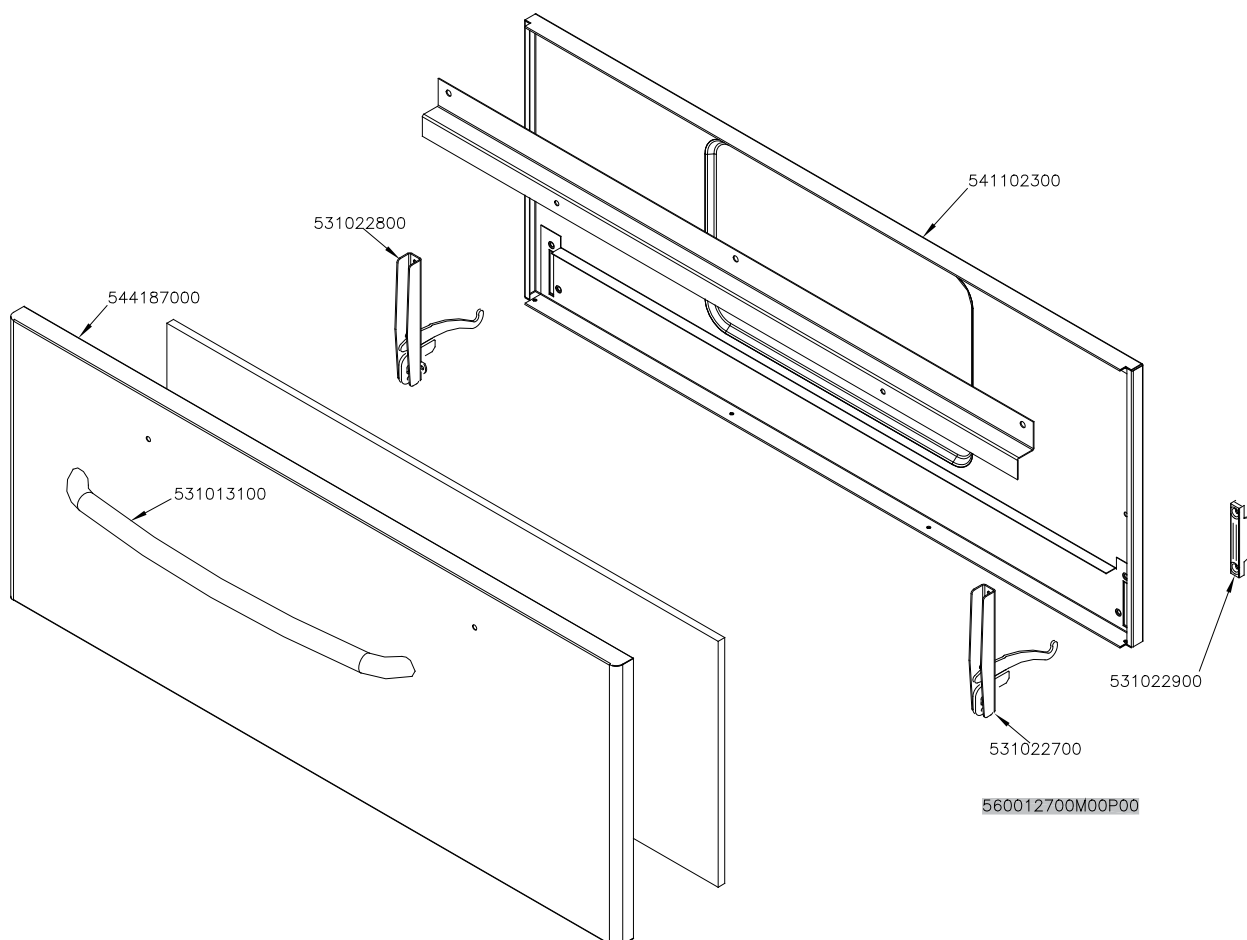

CF8 - 916 ETV, CFQ8 - 916 ETV

(2)

Platný od 1.5.2016

do 30.4.2019

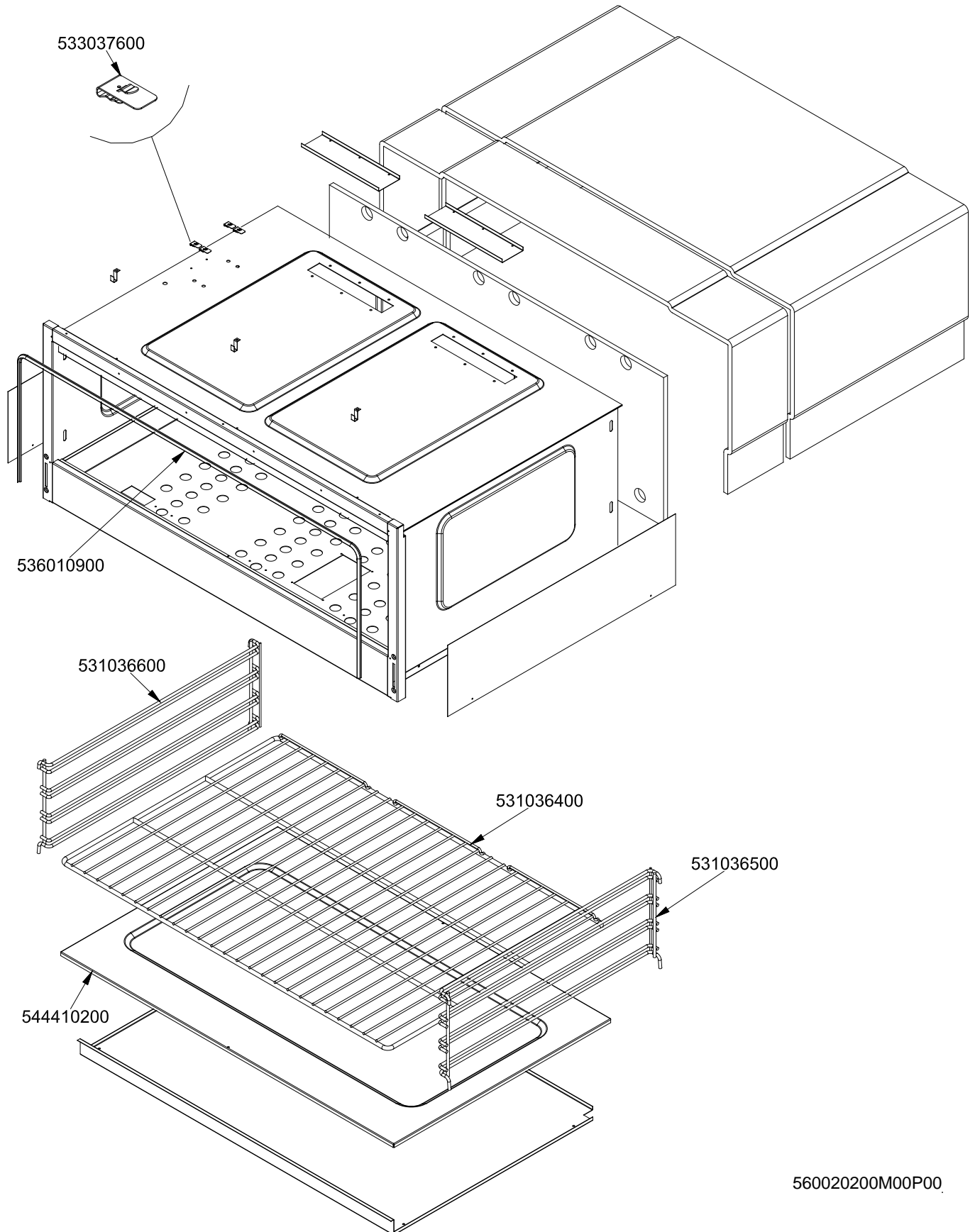



CF8 - 916 ETV, CFQ8 - 916 ETV

(3)

Platný od 1.5.2016

do 30.4.2019

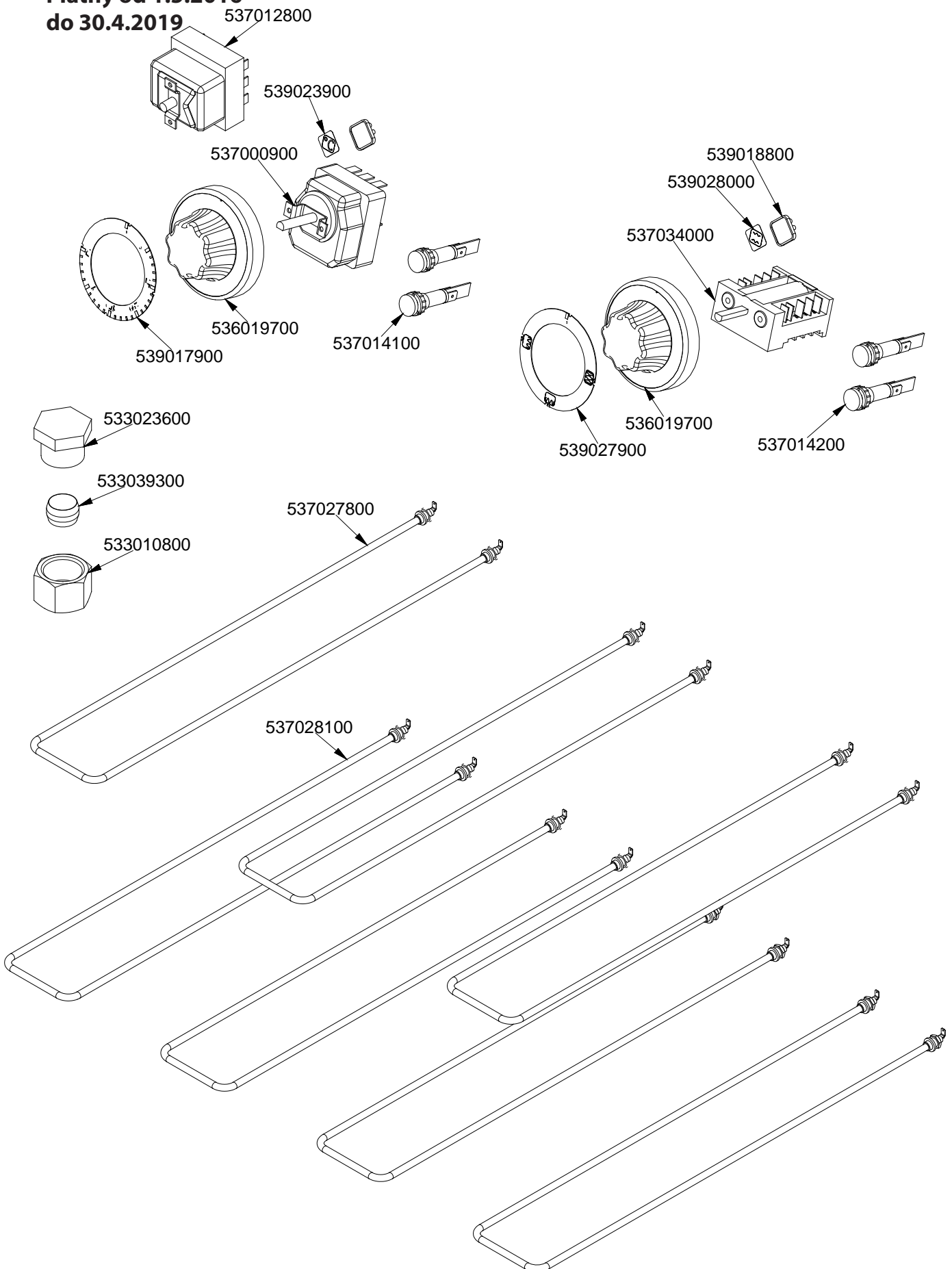



CF8 - 916 ETV, CFQ8 - 916 ETV

(3)

Platný od 1.5.2016

do 30.4.2019

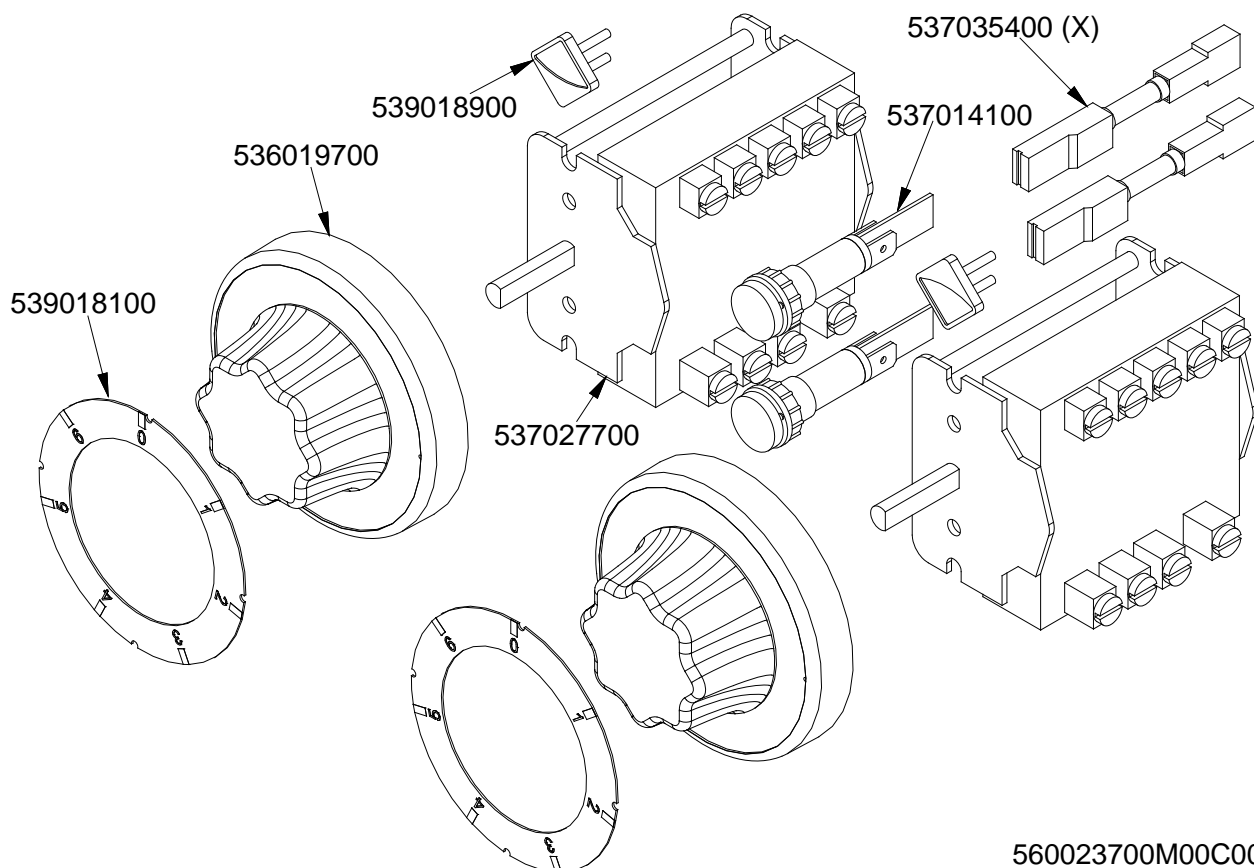

560023700M00C00

CF8 - 916 ETV, CFQ8 - 916 ETV
dveře N°od 0602
Platný od 1.5.2016
do 30.4.2019

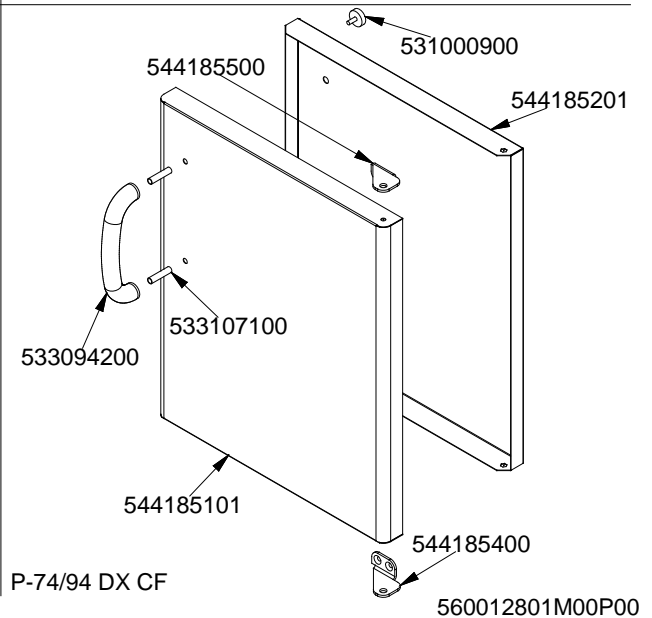
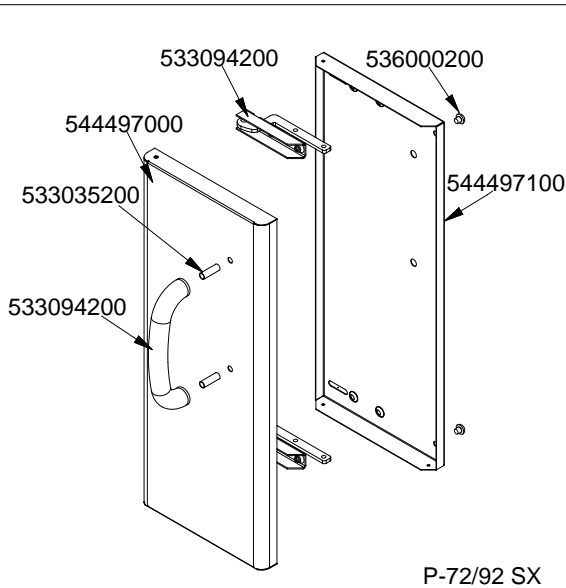
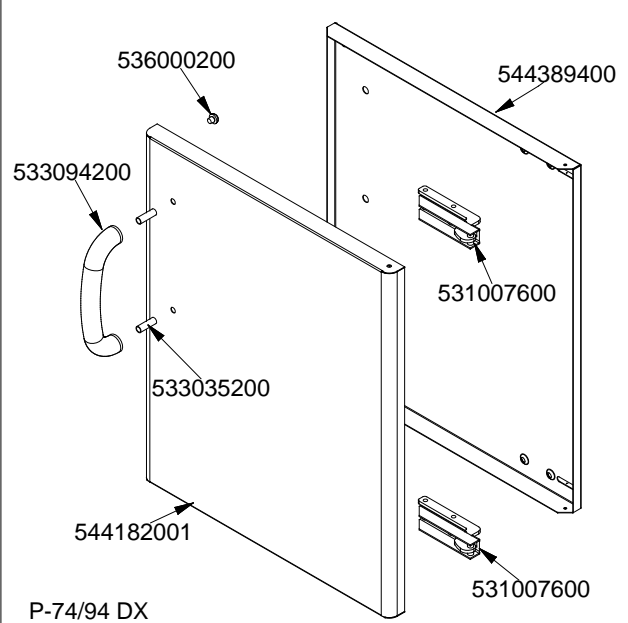
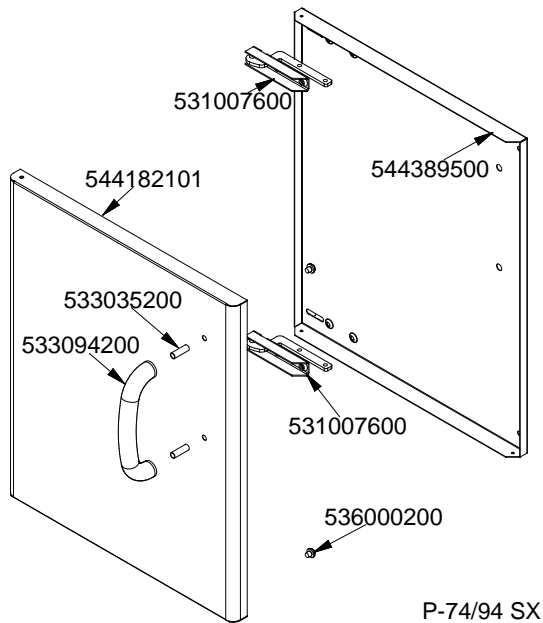
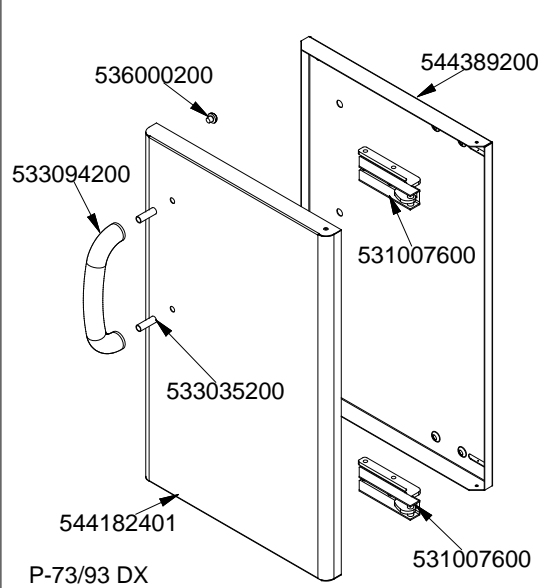
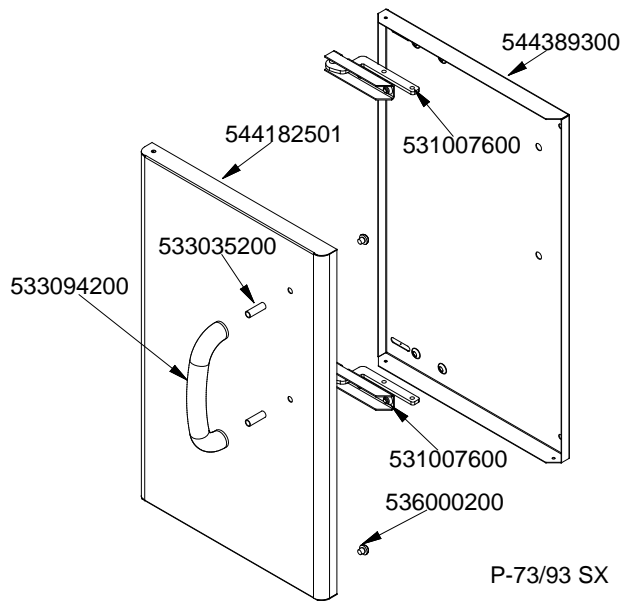

CF8 - 916 ETV, CFQ8 - 916 ETV
dveře N°do 0601
Platný od 1.5.2016
do 30.4.2019

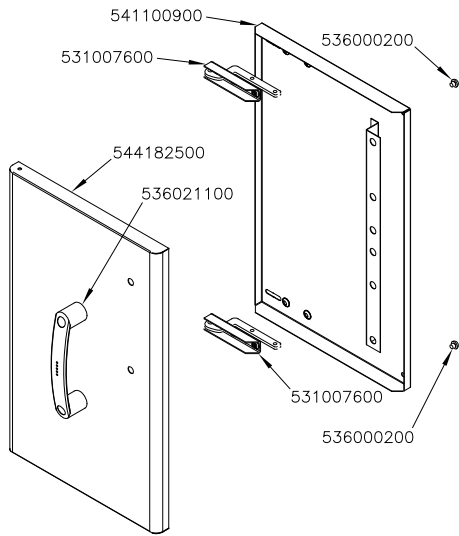

P-73/93 SX

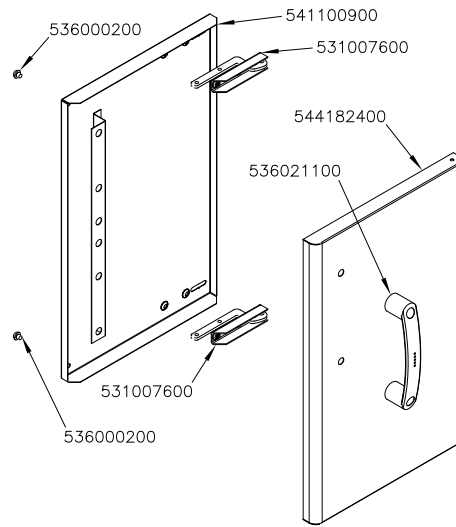

P-73/93 DX

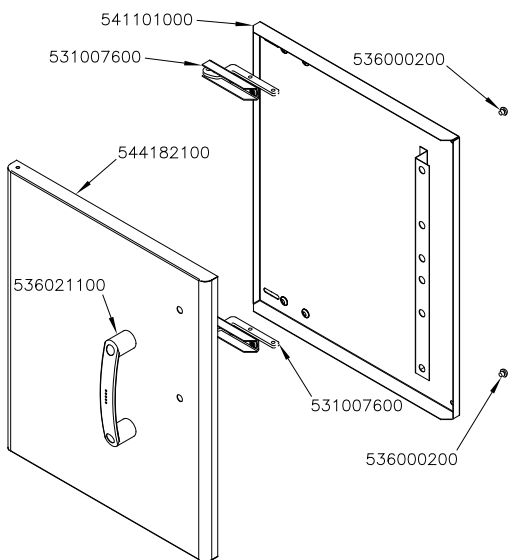

P-74/94 SX

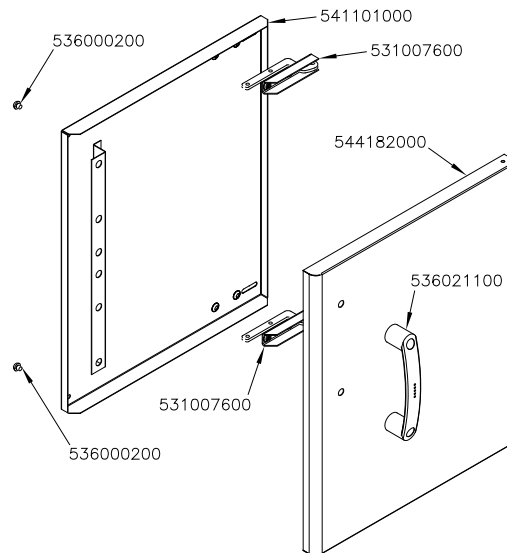

P-74/94 DX

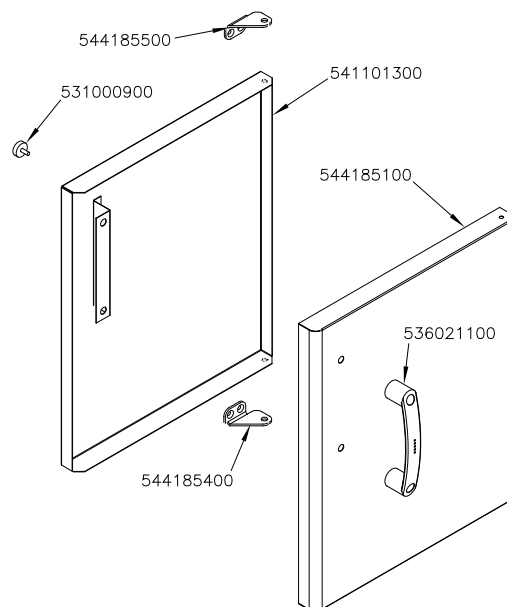

P-74/94 DX CF

560012800M0P00