

PCQT-916ET

2021_11

1

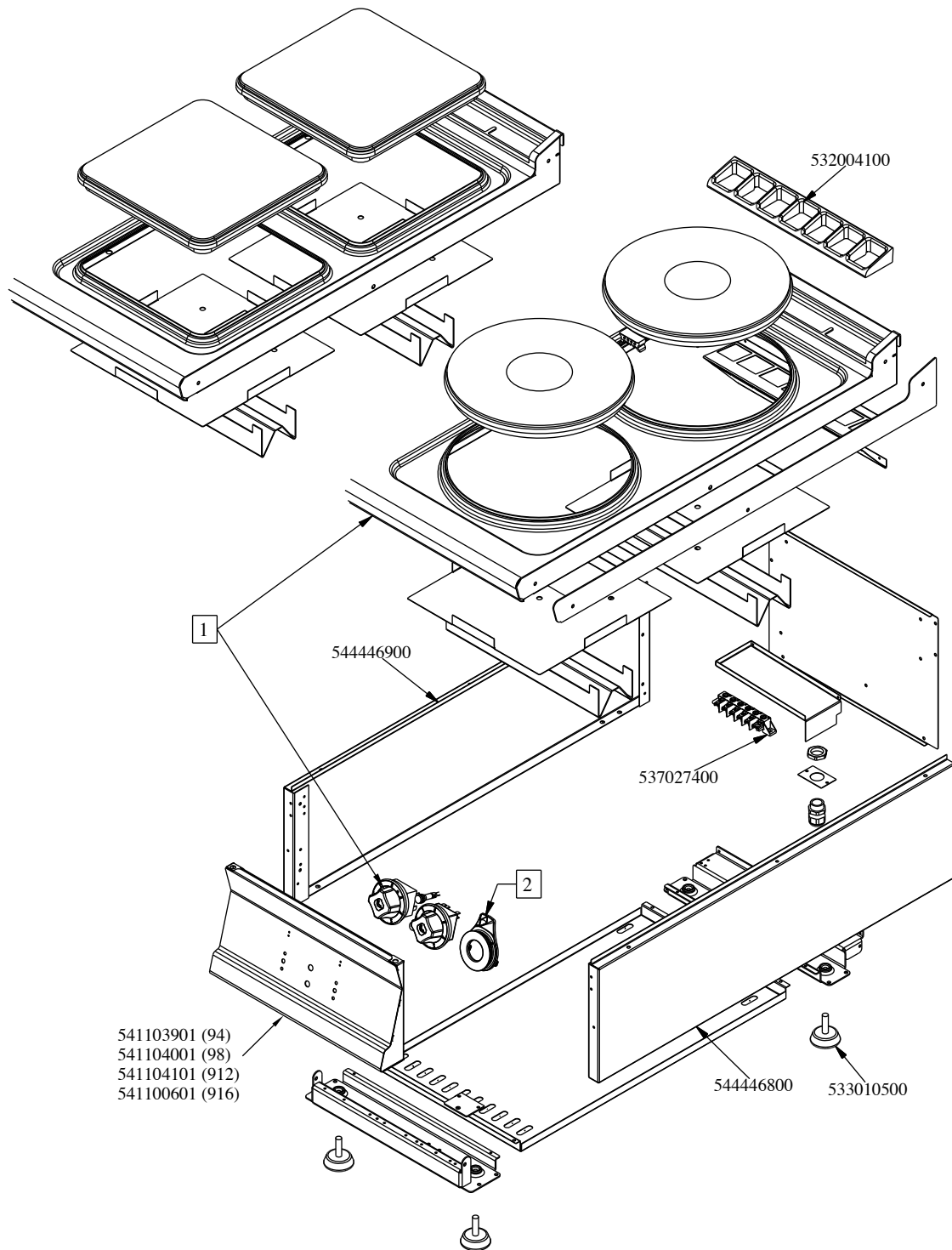



PCQT-916ET

2021_11

1

Kod	Nazev
544446800	FIANCO APP.S90T DX
533010500	LEG M10*25 D.40
537027400	TERMINAL BLOCK THREEPHASE 40A
544446900	LHD SIDE FOR 90T APPLIANCES
532004100	FLUE GRID L=370 90LINE (RAF)
541100601	UPPER PLATE S70 FTL-712ES (RIC)

PCQT-916ET

2021_11

2

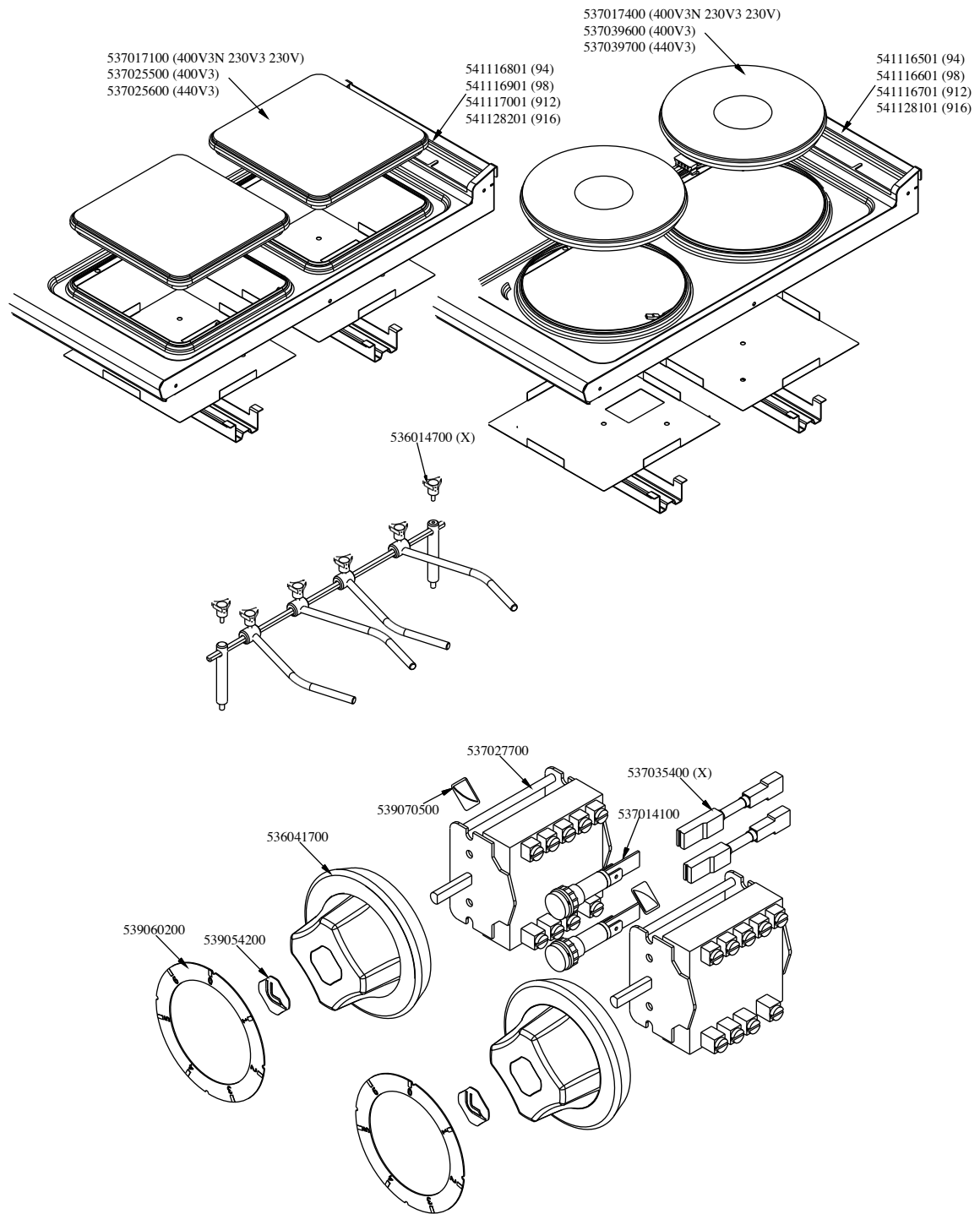



PCQT-916ET

2021_11

2

Kod	Nazev
539070500	ADHES.LABEL FOR RING RED SIGN.
537014100	WHITE WARNING LIGHT 250V
537035400	HEATING ELEMENT 00003W 330KOHM W/F
537027700	COMMUTATOR 7 POSITIONS S.43 32A
536041700	SILVER CHROM. KNOB Ø77 4P.G.Ø06X4,6
539054200	STAMP Ø20,5 CR."L" LOTUS R.
539060200	RED ADESIVE DISK FOR PC-E
536014700	3 DRILL WHEELS
537017100	PLATE 300X300 W4000 V230
537025500	PLATE 300X300 W4000 V400
537025600	PLATE 300X300 W4000 V440
537017400	ELECTRICAL PLATE D.300 W3500 V230
537039600	ELECTRICAL PLATE D.300 W3500 V400
537039700	ELECTRICAL PLATE D.300 W3500 V440
541116501	ASS.PIANO S90 PC-94E
541116601	ASS.PIANO S90 PC-98E
541116701	ASS.PIANO S90 PC-912ET
541128101	ASS.PIANO S90 PC-916ET
541116801	ASS.PIANO S90 PCQ-9 4E
541116901	ASS.PIANO S90 PCQ-9 8E
541117001	ASS.PIANO S90 PCQ-912E
541128201	ASS.PIANO S90 PCQ-916E

PCQT-916ET

2021_11

3

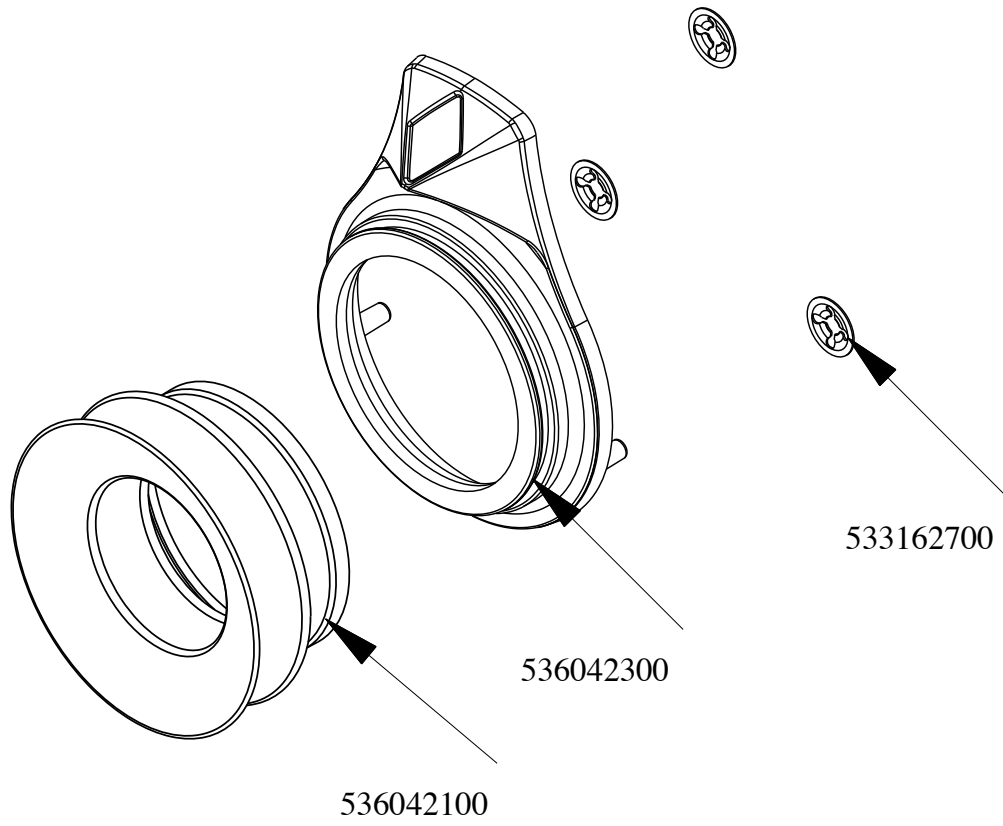



PCQT-916ET

2021_11

3

Kod	Nazev
536042300	SILVER CHROM. RING FOR KNOB Ø77 4 P
536042100	SEAL CASING FOR KNOB Ø77 4 P
533162700	PROCESSING CODE